

DRAPER[®]

PETROL
CHAINSAW
02567

IMPORTANT: PLEASE READ THESE INSTRUCTIONS CAREFULLY TO ENSURE THE SAFE AND EFFECTIVE USE OF THIS PRODUCT.



INSTRUCTIONS

These instructions accompanying the product are the original instructions. This document is part of the product, keep it for the life of the product passing it on to any subsequent holder of the product. Read all these instructions before assembling, operating or maintaining this product.

This manual has been compiled by Draper Tools describing the purpose for which the product has been designed, and contains all the necessary information to ensure its correct and safe use. By following all the general safety instructions contained in this manual, it will ensure both product and operator safety, together with longer life of the product itself.

All photographs and drawings in this manual are supplied by Draper Tools to help illustrate the operation of the product.

Whilst every effort has been made to ensure the accuracy of information contained in this manual, the Draper Tools policy of continuous improvement determines the right to make modifications without prior warning.

1. TITLE PAGE

1.1 INTRODUCTION:

USER MANUAL FOR: Petrol Chainsaw

Stock No: 02567

Part No: CSP3940

1.2 REVISIONS:

Date first published February 2018.

As our user manuals are continually updated, users should make sure that they use the very latest version.

Downloads are available from: <http://www.drapertools.com/manuals>

Draper Tools Limited

Hursley Road

Chandler's Ford

Eastleigh

Hampshire

SO53 1YF

UK

Website: drapertools.com

Product Helpline: +44 (0) 23 8049 4344

General Fax: +44 (0) 23 8026 0784

1.3 UNDERSTANDING THIS MANUALS SAFETY CONTENT:

WARNING! – Information that draws attention to the risk of injury or death.

CAUTION! – Information that draws attention to the risk of damage to the product or surroundings.

1.4 COPYRIGHT © NOTICE:

Copyright © Draper Tools Limited.

Permission is granted to reproduce this publication for personal and educational use only. Commercial copying, redistribution, hiring or lending is prohibited.

No part of this publication may be stored in a retrieval system or transmitted in any other form or means without written permission from Draper Tools Limited.

In all cases this copyright notice must remain intact.

2. CONTENTS

1. TITLE PAGE

1.1 INTRODUCTION.....	2
1.2 REVISION HISTORY	2
1.3 UNDERSTANDING THIS MANUAL	2
1.4 COPYRIGHT NOTICE	2

2. CONTENTS

2.1 CONTENTS.....	3
-------------------	---

3. GUARANTEE

3.1 GUARANTEE	4
---------------------	---

4. INTRODUCTION

4.1 SCOPE.....	5
4.2 SPECIFICATION	5
4.3 HANDLING AND STORAGE	5

5. HEALTH AND SAFETY INFORMATION

5.1 GENERAL SAFETY INSTRUCTIONS FOR CHAINSAW USE	6-9
--	-----

6. TECHNICAL DESCRIPTION

6.1 IDENTIFICATION	10-11
--------------------------	-------

7. UNPACKING AND CHECKING

7.1 PACKAGING	12
7.2 WHAT'S IN THE BOX.....	12

8. ASSEMBLY

8.1 ATTACHING/ADJUSTING GUIDE BAR AND CHAIN	13-15
8.2 FUEL & LUBRICATION	15

9. OPERATING INSTRUCTIONS

9.1 COLD STARTING THE ENGINE.....	16-17
9.2 WARM STARTING THE ENGINE	17
9.3 STOPPING THE ENGINE.....	17
9.4 PERSONAL PROTECTIVE EQUIPMENT (PPE).....	18
9.5 HOLDING THE CHAINSAW.....	19
9.6 KICKBACK.....	20
9.7 CHAIN BRAKE.....	21
9.8 CUTTING	21
9.9 FELLING	21-22
9.10 DELIMBING.....	22
9.11 CROSS CUTTING/BUCKING	23
9.12 SAW CHAIN	23
9.13 CHAIN LUBRICATION	24
9.14 SHARPENING.....	24

10. MAINTENANCE

10.1 CARBURETTOR ADJUSTMENT.....	25
10.2 BAR MAINTENANCE.....	25
10.3 AIR FILTER	25-26
10.4 FUEL FILTER	26
10.5 SPARK PLUG	27
10.6 CLEANING, TRANSPORT & STORAGE	27

11. TROUBLESHOOTING

11.1 TROUBLESHOOTING GUIDE.....	28
---------------------------------	----

12. EXPLANATION OF SYMBOLS

12.1 EXPLANATION OF SYMBOLS	29
-----------------------------------	----

13. DISPOSAL

13.1 DISPOSAL.....	30
--------------------	----

DECLARATION OF CONFORMITY ENCLOSED

3. GUARANTEE

3.1 GUARANTEE

Draper tools have been carefully tested and inspected before shipment and are guaranteed to be free from defective materials and workmanship.

Should the tool develop a fault, please return the complete tool to your nearest distributor or contact:

Draper Tools Limited, Chandler's Ford, Eastleigh, Hampshire, SO53 1YF. England.

Telephone Sales Desk: (023) 8049 4333 or:

Product Helpline (023) 8049 4344.

A proof of purchase must be provided with the tool.

If upon inspection it is found that the fault occurring is due to defective materials or workmanship, repairs will be carried out free of charge. This guarantee period covering parts/labour is 12 months from the date of purchase except where tools are hired out when the guarantee period is 90 days from the date of purchase. The guarantee is extended to 12 months for parts only. This guarantee does not apply to normal wear and tear, nor does it cover any damage caused by misuse, careless or unsafe handling, alterations, accidents, or repairs attempted or made by any personnel other than the authorised Draper warranty repair agent.

Note: If the tool is found not to be within the terms of warranty, repairs and carriage charges will be quoted and made accordingly.

This guarantee applies in lieu of any other guarantee expressed or implied and variations of its terms are not authorised.

Your Draper guarantee is not effective unless you can produce upon request a dated receipt or invoice to verify your proof of purchase within the guarantee period.

Please note that this guarantee is an additional benefit and does not affect your statutory rights.

Draper Tools Limited.

4. INTRODUCTION

4.1 SCOPE

This chainsaw is designed for general lopping, limbing and felling of trees and branches.

4.2 SPECIFICATION

Stock No:	02567
Part No:	CSP3940
Engine displacement	37.2cc
Maximum engine performance	1.3kW
Maximum engine speed	11,000min ⁻¹
Recommended speed at idle.....	3,000min ⁻¹
Fuel tank capacity	0.31L
Tank for chain lubricating oil.....	0.21L
Useable cutting length	370mm

Chain

Specified pitch	9.525mm(³ / ₈ " ^{*)}
Specified gauge (thickness of drive links).....	1.27mm(.050")
Type of chain & guide bar.....	Oregon 91p 057X

Drive sprocket

Specified no. of teeth	6
Specified pitch.....	9.525mm (³ / ₈ " ^{*)}
Sound pressure level	92.9dB(A)
Sound power level	106.1dB(A)
Single value noise level (LWA) [†]	112dB(A)
Vibration level.....	6.18m/s ²
Weight (machine only).....	6kg

[†]A-weighted sound pressure level in accordance to 2000/14/EC.

^{††}Use semi-synthetic 2 stroke oil.

4.3 HANDLING AND STORAGE

Care must still be taken when handling and lifting. Dropping this machine will have an effect on the accuracy and may also result in personal injury. This machine is not a toy and must be respected.

The environment will have a negative result on its operation if you are not careful. If the air is damp, components will rust. If the machine is unprotected from dust and debris; components will become clogged: And if not cleaned and maintained correctly or regularly the machine will not perform at its best.

5. HEALTH AND SAFETY INFORMATION

Have this tool repaired by a qualified person. This tool is designed to confirm to the relevant international and local standards and as such should be maintained and repaired by someone qualified; using only original parts supplied by the manufacturer: This will ensure the tool remains safe to use.

5.1 GENERAL SAFETY INSTRUCTIONS FOR CHAINSAW USE

Chainsaws pose a very significant health and safety risk, even to careful and informed operators, for example, the use of a chainsaw in the workplace requires extensive training and certification. The dangers of using and applying a chainsaw should not be taken lightly. Seek guidance, training or employ a professional to carry out the task if uncertain or nervous of the potential risks and dangers involved. **WARNING: Danger of death.**

Personal Protective Equipment (PPE)

- Due to the nature and ferocity of a petrol driven chainsaw, no PPE equipment can provide 100% protection against chainsaw cuts.
- Equipment specifically designed for use with a chainsaw shall be worn, consisting of;
 - Safety helmet (EN 397).
 - Mesh visor (EN 1731).
 - Hearing protection (EN 352).
 - Gloves (EN 381-7) with protective guard on back of left hand.
 - Leg protection (EN 381-5).
 - Non-slip boots (EN 345-2).
 - High visibility jacket.

Leg protection is achieved with a chain clogging material designed to stop the chain before it penetrates fully through and into flesh.

The gloves, boots and leg protection should be marked with the symbol (right) and indicate the chain speed to which they have been tested.



Preparation

- Before use inspect the guide bar grooves for distortion, the guide bar rail for cracks, the nose sprocket teeth condition, chain tension and condition, drive sprocket condition and operation and operation of the chain brake.
- Never operate the chainsaw alone in case of emergency. Have an assistant in visual/communicative range.
- Ensure the site is assessed for risk potential and a safe working distance is marked to prevent bystanders entering.
- In case of accident, ensure means of contact with emergency services are possible and adequate information is available to facilitate an urgent recovery.
- Always carry a basic first aid kit containing large wound dressings.
- Identify all services (e.g. gas, water, electric, phone etc.), particularly overhead before felling commences.
- Ensure a distance of at least twice the tree height is observed from all obstacles and dangers.
- Keep bystanders a minimum of 10M away and all access points into the work area marked accordingly.
- Tree felling must only be carried out by a single individual and only after the danger zones and escape routes have been identified and cleared.
- Do not fell when wind conditions may influence/control the direction.

5. HEALTH AND SAFETY INFORMATION

- Close observation and inspection for dead or diseased wood and insecure limbs or branches must be carried out prior to any cutting. Dead wood can cause unexpected reactions during a routine felling.
- Remove any scrub or other obstructions from the area to enable a quick escape route and ensure visibility of the chain is not impeded during cutting.
- Plan work to reduce manual lifting, i.e. lightest off cuts move furthest.
- If work is a result of wind blow, ensure no unstable trees or limbs pose any further danger.
- Never stand on anything other than the ground.
- When preparing to work on the ground, e.g. cross cutting or limbing, ensure no obstacles are hidden or obscured from view. Contact with such an object can result in loss of footing or kickback from the chainsaw.

Saw operation

- Do not operate the chainsaw without being completely familiar on all safety aspects, functions and most importantly how to stop the chainsaw in an emergency.
- Do not operate the chainsaw above shoulder height.
- Regularly clear cut material as build up will create a hazard under foot.
- Never use the chainsaw if the stop switch is FAULTY or not functional.
- Prior to each use inspect the chainsaw for damage. Ensure all safety features and mechanisms function correctly and that the cutting means is of the type and design as specified by the manufacturer.
- Adopt a secure and balanced stance, bend knees instead of back. Hold the saw close into your body for balance.
- Maintain a good grip with both hands on the saw. The chainsaw is solely designed for operation of the rear handle by the right hand and the left handle on the front handle. Grip the front handle with left thumb underneath to allow resistance in case of kickback.
- Stop the chainsaw before setting it aside.
- Only begin cutting with throttle at maximum.
- Kickback occurs when the chainsaw is stopped suddenly resulting in the tip or the guide bar being violently thrown up towards the operator's head/face. Correct stance and knowledge of the operating procedure can greatly reduce that risk.
- Operate the chain brake before moving with the saw. If moving more than a short distance, stop the saw and refit the bar guard.
- **WARNING:** during and after use, take care not to touch the hot engine parts, in particular the exhaust muffler.
- Do not attempt to use the chainsaw if tired, ill or under the influence of alcohol or other drugs.

5. HEALTH AND SAFETY INFORMATION

Felling

- Remove lower branches/limbs from the tree up to shoulder height.
- When removing the lower branches ensure the operator is protected from kickback by using the tree stem for protection and keeping the guide bar out of line with the body (off set).
- Ensure there is sufficient fuel in the tank to safely complete the felling cut.
- Never leave a partially felled tree.
- When the tree begins to fall move back and away at 45° as quickly as possible. Branches on the underside of the tree can cause the stem to move sideways or backwards dangerously.
- In the event of a tree becoming hung in another tree or obstacle seek assistance from a professional. A hung tree poses many dangers and creates more potential risks than felling a normal tree. Do not abandon a hung tree, walk under or attempt to climb one.
- Always perform a notch cut followed by a felling cut to create a felling hinge. Felling wedges or levers may be necessary to prevent the chainsaw from becoming pinched in the felling cut.

Limbing

- Ensure the tree is stable before any limbing commences.
- The ideal working height for performing limbing is between waist and knee height.
- Stand on the left side of the stem, working from the root upwards, then return down the other side.
- Use the top (pushing chain) and bottom (pulling chain) to make the cuts, constantly taking note of the bar tip in conjunction with limbs further round the stem which may be less visible or obscured.
- Ensure the tip of the bar does not come into contact with the ground.
- If the felled tree is on a slope always remain above the tree in case the removal of a limb were to cause potentially dangerous movement.
- Rest the weight of the saw on the tree where possible.
- Take care of limbs and undergrowth under tension as there is a danger of spring back once the cut has been performed.
- At regular intervals, stop the chainsaw and clear the cut debris to maintain a firm footing.

Cross cutting

- The timber must be raised off the ground with supports to perform a safe cut.
- When working on slopes, always work above the timber in case of movement.
- Always adopt a good firm footing.
- Observe the timber to assess the surfaces for tension.
- Tension and compression in supported timber can result in the timber splitting or pinching the guide bar if incorrectly cut.
- Alleviate tension in the timber by making an initial cut (1/3) into the compressed surface before finishing the cut (2/3) into the tension surface.
- Stand off to the side of the saw in case of kickback.
- If the chainsaw becomes trapped, switch off immediately before attempting to free the guide bar. Use the correct tools when attempting to free a trapped saw.
- Be ready to step back quickly in case of the timber rolling.
- Ensure no debris is present in the work area.

5. HEALTH AND SAFETY INFORMATION

Maintenance

- Never modify the chainsaw in anyway.
- Always maintain the chainsaw in good working order regularly serviced by an authorised service agent.
- Ensure the handles remain clean and free from oil, fuel & moisture.
- Only use replacement parts supplied by the manufacturer.
- Ensure the chain does not rotate while the saw is at idle.
- All safety devices must remain fitted, functioning and where possible serviced. Especially the chain brake.
- Only use fresh, clean and good quality fuel/oil mix in the chainsaw.
- Regularly inspect the chain lubricant level, regularly topping up. When the chainsaw is running at high speed the chain oil will dispel quicker and require checking/adjusting more frequently.
- Never operate the chainsaw without chain oil.
- Never operate the chainsaw with a maladjusted or blunt chain as this is highly dangerous.
- When the chainsaw has warmed up, stop the chain & engine before checking/adjusting the tension.
- Never refuel in close proximity to naked flames, sparks or other sources of ignition, e.g. cigarettes.
- Allow the engine to cool before refuelling. Avoid spillage while refuelling.
- Wipe up and correctly dispose of any fuel spillage immediately with a suitable medium.
- Ensure the correct ratio of fuel and oil are used.
- Do not set down a hot chainsaw on or near easily combustible materials. e.g. dry leaves and grass.
- Move away from the refuelling area before restarting the chainsaw.
- Store fuel for short periods only and avoid mixing more than is required. Store in a container specifically designed for petrochemical applications away from heat and direct sun light.
- Prior to use check for chain oil distribution on a piece of paper or cut timber. Observe spatter before continuing.
- After each use clean the chainsaw thoroughly.
- Regularly check external nuts and fixings to ensure vibration caused by normal use has not begun to loosen them.
- Periodically remove all shavings and sawdust from the visible parts of the chain brake mechanisms.

Storage

- Thoroughly clean/service the chainsaw and refit the bar guard. Remove the spark plug ignition lead from the back of the spark plug and position the lead to avoid accidental reconnection.
- Locate the machine out the reach of children, in a dry locked unit.
- Remove all residual fuel from the fuel tank before storing.

6. TECHNICAL DESCRIPTION

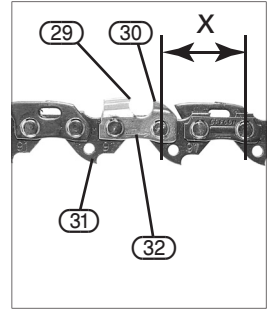
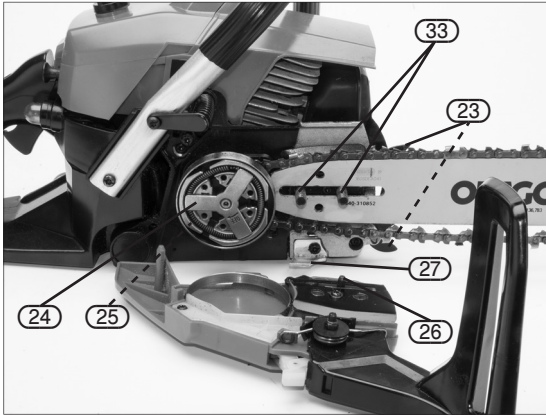
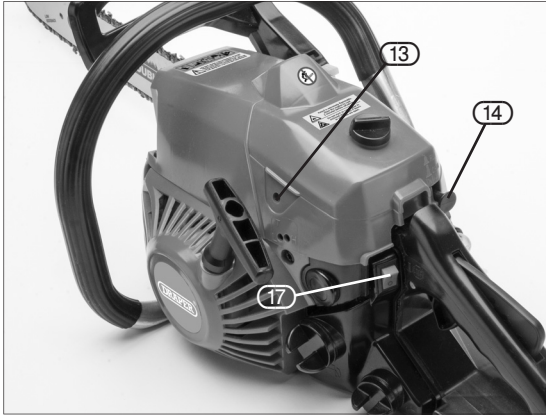

Warning:

*Fuel mixing bottle is designed to allow the user to easily mix two-stroke oil with petrol. It is not designed to store or transport petrol/petrol oil mix.

The chemical and physical properties of petrol/petrol oil mix are such that the seals on this bottle may leak. **Do not use this bottle for storage or transportation.**

Contact Draper Tools for suitable storage containers.

6. TECHNICAL DESCRIPTION

6.1 IDENTIFICATION

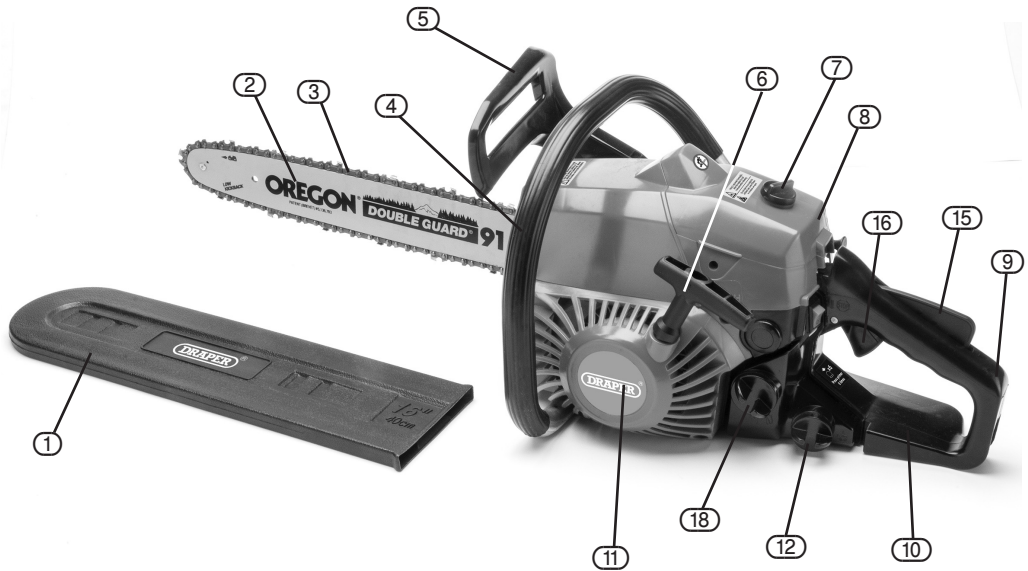

- ① Bar guard.
- ② Guide bar.
- ③ Chain.
- ④ Wrap around handle.
- ⑤ Chain brake lever (Front hand guard).
- ⑥ Recoil starter cord.
- ⑦ Top cover screw.
- ⑧ Top cover.
- ⑨ Rear handle.
- ⑩ Rear hand guard.
- ⑪ Recoil starter.
- ⑫ Chain oil tank cap.
- ⑬ Carburettor set screw (Idle speed adjuster).
- ⑭ Choke.
- ⑮ Throttle trigger lock out.
- ⑯ Throttle trigger.
- ⑰ Stop switch.
- ⑱ Fuel tank cap.
- ⑲ Primer.
- ⑳ Muffler (silencer).
- ㉑ Bar locking nuts.
- ㉒ Clutch cover.
- ㉓ Spiked bumper.
- ㉔ Clutch.
- ㉕ Drive sprocket.
- ㉖ Chain tension adjuster (pin).
- ㉗ Chain catcher.
- ㉘ Chain tension adjuster (screw).
- ㉙ Cutter.
- ㉚ Depth gauge.
- ㉛ Drive link.
- ㉜ Direction of rotation arrow.
- ㉝ Bar locking threads.

7. UNPACKING AND CHECKING

7.1 PACKAGING

Carefully remove the chainsaw from the packaging and examine it for any sign of damage that may have happened during shipping. Lay the contents out and check them against the parts shown below. If any part is damaged or missing; please contact the Draper Helpline (the telephone number appears on the Title page) and do not attempt to use the machine.

The packaging material should be retained at least during the guarantee period: in case the machine needs to be returned for repair.

Warning! Some of the packaging materials used may be harmful to children. Do not leave any of these materials in the reach of children.

If any of the packaging is to be thrown away, make sure they are disposed of correctly; according to local regulations.

7.2 WHAT'S IN THE BOX?

As well as the petrol chainsaw there are several attaching parts.

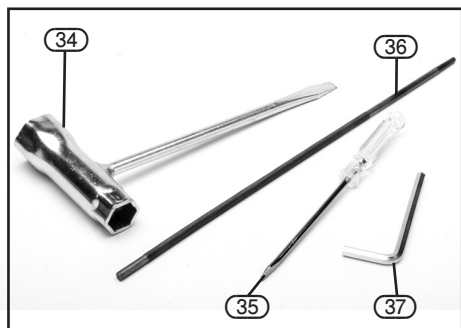

(34) Combination box spanner.

(35) Screwdriver.

(36) Chainsaw file.

(37) Hexagon key.

8. ASSEMBLY

Warning: Do not start the chainsaw before mounting and correctly adjusting the guide bar and chain.

Attention: Saw chain is extremely sharp - wear gloves when handling chain.

8.1 ATTACHING/ADJUSTING GUIDE BAR AND CHAIN - FIGS. 1 - 9

Position the power head as shown (Fig.1). Ensure the chain brake is disengaged. To disengage, pull the chain brake lever (5) towards the front wrap round handle.

With the combination box spanner, remove the two guide bar locking nuts (21).

Use a cross slot screwdriver to loosen the chain tension adjuster screw (28) anti-clockwise retracting the chain tension adjuster pin (26). Pull the clutch cover away and off the machine.

– Fit the chain behind the clutch and around the drive sprocket paying particular attention to the cutter orientation. An incorrectly fitted chain is dangerous.

– **Note:**
The chain is driven on the top of the guide bar away from the power head. Stamped on the saw chain cutters and links is a direction of rotation arrow. Ensure the drive sprocket teeth have correctly meshed with the drive links.

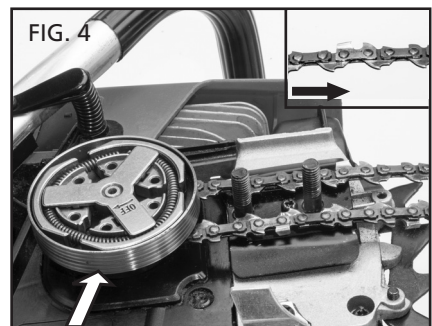
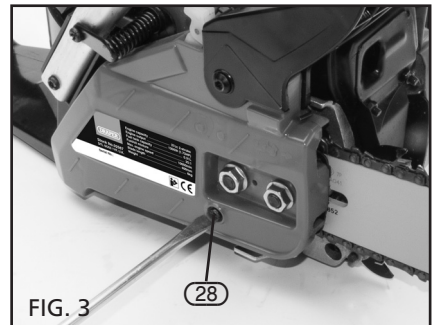
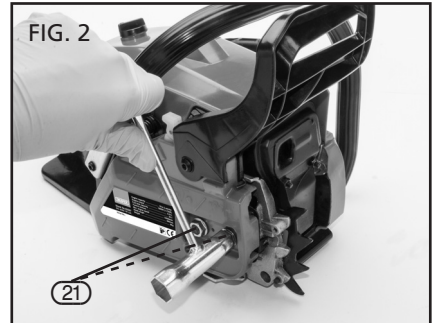
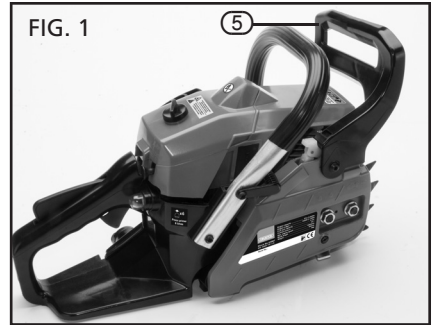

8. ASSEMBLY

- Position the guide bar (2) on to the bar locking threads (33). Locate the chain tension adjuster pin (26) into aperture on the guide bar.

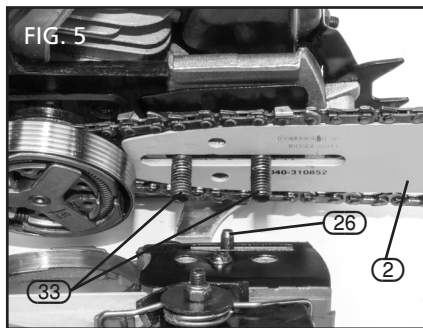

- Slot all the drive links in to the guide bar groove. Mesh the drive links at the tip of the bar correctly round in to the nose sprocket teeth.
- Slide the guide bar away from the bar head to put some tension on the saw chain.



- With the screwdriver, tighten the chain tension adjuster screw clockwise. For initial tension before refitting the clutch cover. Ensure the chain and guide bar do not come apart while fitting the clutch cover. Also ensure the drive links have not separated from the sprockets.
Tighten the clutch cover nuts by hand ONLY at this time, to allow further chain tensioning and adjustment.

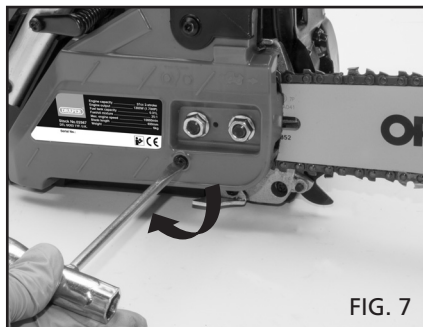

- Check the chain tension half way along the guide bar by pulling the drive links out of the groove. Continue tightening the chain tension until only a complete drive link (31) is visible.

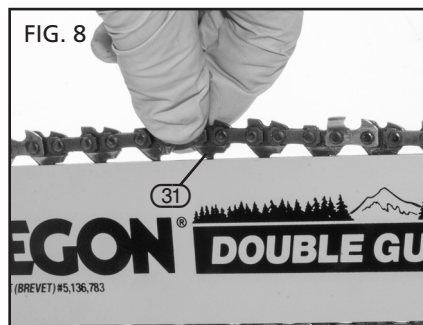

8. ASSEMBLY

- Elevate the tip of the guide bar, keeping light pressure down on the front of the power head while tightening the clutch cover nuts fully.
- When secure, ensure the chain brake is disengaged and check to see that the chain runs freely in the guide bar groove.
- When operating a new saw chain, stop and check the tension after a few minutes work (with the engine stopped and blade brake applied). This is necessary due to initial stretch being taken up in the chain links.
- **WARNING:** A loose saw chain is dangerous and may result in a serious accident.



8.2 FUEL & LUBRICATION - FIGS. 10 - 11

This chainsaw is equipped with a 2 stroke air cooled petrol engine.

This type of engine requires a mixture of fuel and oil to perform and function. Failure to use the correct oil, fuel or mixture ratio will cause permanent damage to the engine. Only use fresh, clean, good quality unleaded fuel mixed with a high quality 2 stroke oil. Do not use any other types of oil e.g. engine oil as this will cause damage to the engine.

A mix ratio of 25:1 must be used. To mix a ratio of 25:1, add 0.2 litres (200ml) of 2 stroke oil into 5 litres of unleaded fuel (2.5%).

- **Attention:** Always handle fuel with caution. Pour the fuel/oil mixture into a specifically designed mixing receptacle before replacing the cap and shaking gently. Remove the fuel tank cap (18) by turning it anti-clockwise. With the aid of a funnel pour the fuel/oil mixture into the fuel tank before replacing the cap firmly. Avoid spillage and do not over fill.
- **Note:** Always mix and refuel in a well ventilated area away from sources of ignition.

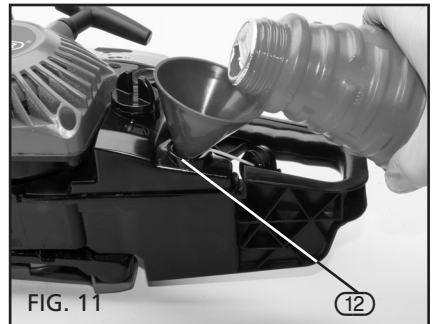
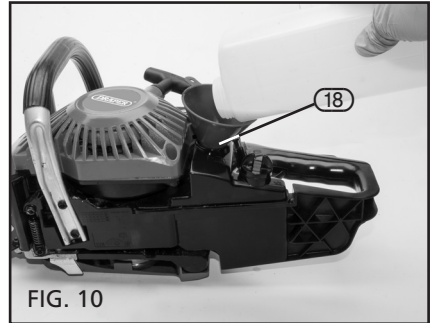

- The chain lubrication system must provide a continuous flow of specific oil onto the guide bar and chain. No lubricating oil at all will result in damage to the guide bar. Overheating will generate smoke.
- Only use oil specifically designed for lubricating chainsaw guide bars and chains.
 - Remove the chain oil tank cap (12) by turning it anti-clockwise.
 - With the aid of a funnel pour the lubricant into the oil tank, before replacing the cap firmly.
 - Do not use 2 stroke oil, engine oil or used oil.
 - Wipe any spilt fuel or oil immediately.

9. OPERATING INSTRUCTIONS

Warning: Chainsaws pose a very significant health and safety risk even to careful and trained operators.

9.4 PERSONAL PROTECTIVE EQUIPMENT (PPE) - FIG. 16

Due to the nature and ferocity of a petrol driven chainsaw, no PPE can provide 100% protection against chainsaw cuts.

Equipment specifically designed for use with a chainsaw shall be worn, consisting of:

- A safety helmet with mesh visor and ear defender to protect against falling/thrown debris and the high levels of noise generated.
- Gloves with additional protective guard material on the back of the left hand to defend against chain whip in the event of breakage.
- Trousers or chaps with leg protection incorporated into the front/side. In case of contact with a moving saw chain the clogging material is designed to stop the chain before it penetrates fully through and into flesh.
- Safety boots with a good non-slip tread incorporating protection to toes & shins.
- High visibility jacket. Some jackets incorporate the clogging material like the trousers, but in any event should be close fitting.

All this equipment should be tested to relevant international and European standards and marked accordingly. The gloves, boots and trousers should be additionally marked with  symbol, also indicating the chain speed to which they have been tested.

Attention: Fully read and understand the general safety instructions section of this manual before proceeding.

FIG.16



9. OPERATING INSTRUCTIONS

- Grip the rear handle (9), covering the throttle trigger lockout (15) with the palm of your hand. Pull the throttle (16) to release the throttle advance. The engine will now idle at normal tick over.
- If pausing for more than a few seconds, engage the chain brake. Do not move more than three paces without engaging the chain brake and stopping the engine.
- Transport the chainsaw with the bar guard in place.

Warning: The saw chain continues to move for a period after the throttle has been released.

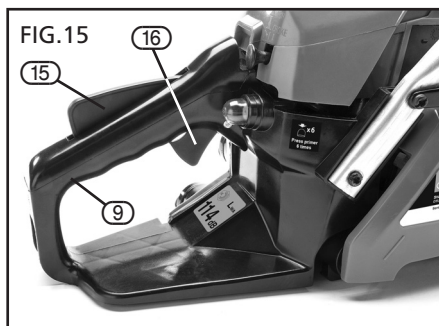

9.2 WARM STARTING THE ENGINE

- Position the stop switch up. Pull out the choke to engage the throttle advance (midway position).
- Pull the recoil starter cord to start the engine.
Operate the throttle trigger lockout and throttle to release the throttle advance.

9.3 STOPPING THE ENGINE

To stop the engine depress the stop switch in to the “O” position.

NOTE: If the chainsaw has been running at full speed for a prolonged period allow the saw to idle for a few minutes before stopping the engine.

The engine shall be stopped while carrying out any other operation such as:

- Refuelling.
- Topping up chain oil.
- Making checks or adjustments.
- Cleaning.
- Moving from one place to another by foot.
- Transporting.

9. OPERATING INSTRUCTIONS

Warning: Do not start the chainsaw until it is fully assembled, correctly adjusted and all functions and controls are familiar.

9.1 COLD STARTING THE ENGINE - FIGS. 12 - 15

Before starting, disengage the chain brake. Rest the chainsaw on a stable surface. Depress the stop switch (17) into the on position "I" and pull out the choke lever (14) fully. Pump the primer (19) repeatedly until fuel is visible in the bubble. This moves fuel up the lines to the head.

- Pass your foot through the rear handle and stand on the hand guard. Firmly hold the front wrap around handle. With the other hand grip the recoil starter cord. Ensure the chain and bar are free and not touching any objects. Pull the starter using short, sharp movements.

Note: Do not use the full length of the recoil starter cord as this can cause breakage or premature failure. Do not release the starter cord to recoil on its own. Damage will occur to the mechanism.

Once the engine tries to fire, push the choke lever to the midway (throttle advance) position. Continue operating the recoil starter cord until the engine starts.

Caution: The chain will start rotating as the throttle is partially advanced.

Note: If there is a strong smell of fuel this indicates that the engine may be flooded. Wait a few minutes before attempting to restart the machine as if the engine were warm i.e. no choke.

When running, hold the chainsaw firmly allowing it to warm for 20 seconds (pre heat).

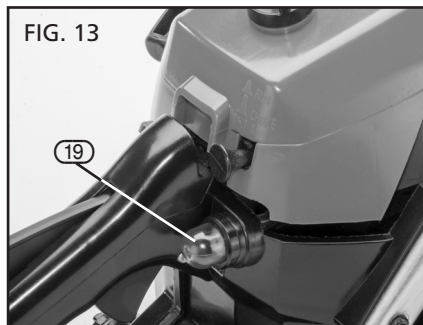
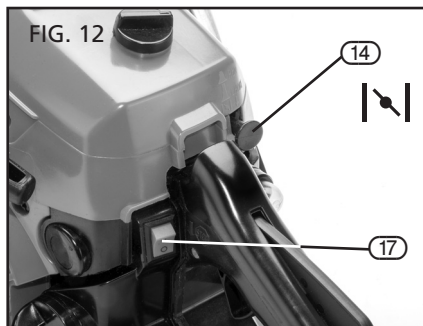

9. OPERATING INSTRUCTIONS

9.5 HOLDING THE CHAINSAW - FIGS. 17 & 18

Do not be afraid to hold the chainsaw power head close in to the body. In this position the weight of the saw will be easy to bear and in the event of a kickback will be more controllable. Firmly grip the rear handle pulling it tight in to hip/thigh. With the left hand grip the front handle with thumb on the underside. In this position with the body turned slightly towards the saw, should a kickback occur the left arm will be stronger to brace against the force of the kickback, or if unable to withstand, the saw chain should avoid the face/head.

Try to work at hip height, or bend the knees instead of the back. This will be more comfortable and a safer stance to adopt.

FIG.17



FIG.18

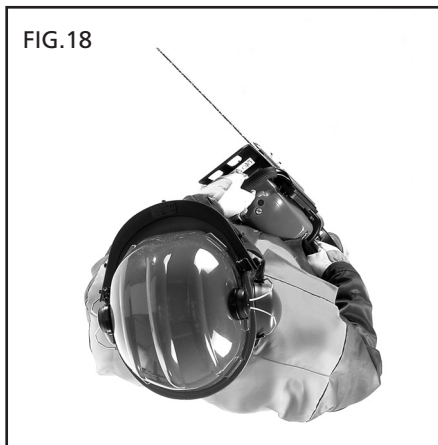

9. OPERATING INSTRUCTIONS

9.6 KICKBACK - FIG.19

Definition:

Kickback: Rapid upward and/or backward motion of the chainsaw which can occur when the moving saw chain near the tip of the guide bar contacts an object such as a log or a branch.

Kickback is the most common hazard associated with chainsaws and can result in serious injuries, and even fatalities.

- This chainsaw features an inertia activated chain brake and a manually triggered chain brake. In the event of a particularly strong kickback inertia generated releases the brake lever triggering the chain brake. If the kickback is less the chain brake lever will activate on the operator's left hand (hence the necessity to always operate the saw two handed). There are different types of kickback and a couple of other associated risks.
- Because the saw chain is driven along the top of the guide bar away from the power head, contact with the kickback zone can translate the chain movement in the opposing direction on the guide bar. This is particularly the case if the chain becomes pinched or snags in the kickback zone of the guide bar.
- Another kickback danger can result in the chainsaw being forced horizontally back towards the user. Kickback of this nature is the result of the chain along the top of the guide bar being pinched, translating the force backwards through the guide bar.
- The opposite of kickback is having the chainsaw pulled away. Pull-in can be a result of the chain pinching along the bottom of the guide bar. As the chain along the bottom of the guide bar is returning to the power head the translating force pulls the chainsaw from the operator's hands.
- In addition to kickback, risks such as skating and bouncing can lead to a loss of control of the chainsaw. If the chain fails to make an initial incision it can move sideways along the timber 'skating' or 'bouncing'. This sideways movement can result in off balancing, overstretch, further loss of control or contact with the guide bar tip on another limb causing a kickback.
- To avoid kickback occurring, do not use the tip of the guide bar. Take note of foreign objects and other branches/limbs close to the area being cut.
NOTE: They may not be in your line of sight. Always make the initial cut on the tension surface of the timber and use non metal spreading wedges to avoid the timber pinching the chain. Always begin cutting at full speed and ensure the body of the saw, in particular the spiked bumper, is against the timber.
- Cut only one piece of timber at any time and observe the timber while making the cut to ensure the tension was assessed correctly. Hold the chainsaw firmly as described. Maintain a good firm stance and do not over reach. Do not cut above shoulder height. The use of a low kick back saw chain is also advised. These are designed specifically to help reduce the factors leading to kick back. Do not solely rely on the chain brake to stop an accident occurring or chainsaw ppe to avoid injury. They are a deterrent.

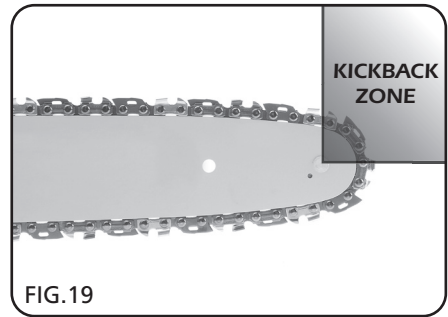

9. OPERATING INSTRUCTIONS

9.7 CHAIN BRAKE - FIG.20

Before starting any cutting, manually check the chain brake lever functions correctly moving backward and forward. Make these checks with the saw pre-heated and at tick over.

- If the chain brake is not working correctly or fails to operate at all, immediately switch off the engine. Do not attempt to operate the chainsaw until this has been resolved and the safety device is operational again. Have chain brake checked by an authorised service agent regularly to ensure integrity of serviceable parts. A worn brake mechanism is dangerous.



9.8 CUTTING

Once all the preliminary checks have been thoroughly carried out, to ascertain the correct functionality of the chainsaw and its various components, preparation for cutting can commence. See the general safety instruction section for details.

- Immediately after any cutting operation release the throttle to return the chainsaw to idle.
- Do not force the chain to cut. A sharp chain should be left to cut at its own pace.

9.9 FELLING - FIGS. 21 - 23

Refer to general safety instructions for preparation & specific warnings.

- Always seek information from the local authority prior to cutting down any tree as regulations, laws and protection orders may affect or prohibit the work involved.
- To fell a tree safely many factors need taking into account and some preparation is also necessary. A safe perimeter at least 2½ times the height of the tree must be established warning of the activity taking place and preventing bystanders from entering.
- The direction of a falling tree can be influenced but not guaranteed. Roads, footpaths and services like overhead power/phone cables all present problems which need addressing.
- If unable to safely and satisfactorily resolve these issues, have a certified trained professional carry out the tree felling.
- The direction can be changed from that intended by factors such as wind, sloping terrain, tree growth (leaning, heavy limb structure one side and decay) etc. Failure to observe these factors or account for them can result in severe injury or fatality.
- Plan an escape route and ensure all scrub, debris and undergrowth is cleared so an unimpeded escape can quickly be made to safety if the felling direction unexpectedly changes.

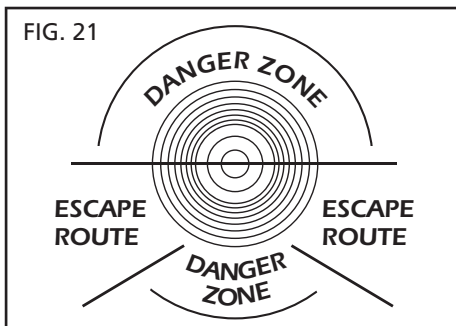

9. OPERATING INSTRUCTIONS

- Delimb the tree up to shoulder height of all branches. If the tree has large buttress roots (Q) also remove these to enable the direction notch to be cut as close to the ground as possible.

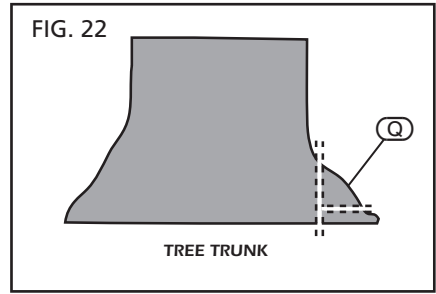

- The direction notch (R) should be started at 45° down into approximately one third the trees diameter. Cut the bottom of the notch at 90° and remove the wedge. On the opposite side of the tree and 5cm higher than the bottom of the notch, the felling cut (S) should be made at 90°. This cut must be made in one go and stop 5cm from the back of the notch. This creates the hinge which is very important as it helps control the felling. The hinge (T) must be parallel. Use the spiked bumper to obtain a firm grip and leverage while performing these cuts.

The use of wedges should be employed to prevent the saw becoming pinched and to complete the fell safely.

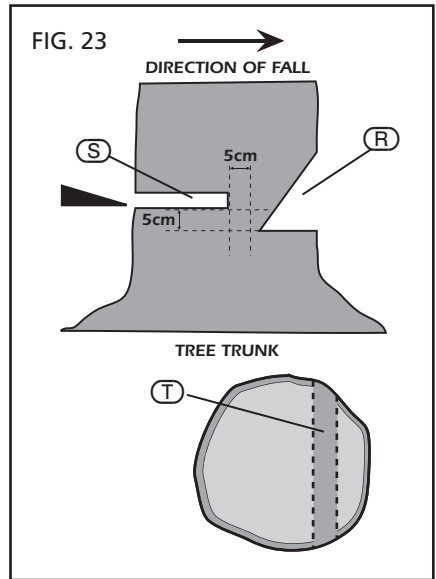

9.10 DELIMBING - FIG. 24

Refer to general safety instructions for preparatory and specific warnings.

- When removing smaller branches with a single cut, keep the tree between you and chain.
- For larger limbs make three cuts. The initial cut (U) in the tensioned underside of the limb one third of the way through. Use a pushing chain (the top of the guide bar) for this.
- The second cut (V) will be made all the way through with the underside of the guide bar.
- The third cut (W) is only necessary if the tree is not being felled, to leave a neat collar.
- On a felled tree always work from butt to tip with the tree on your right side. Always work with the trunk between you and the guide bar.

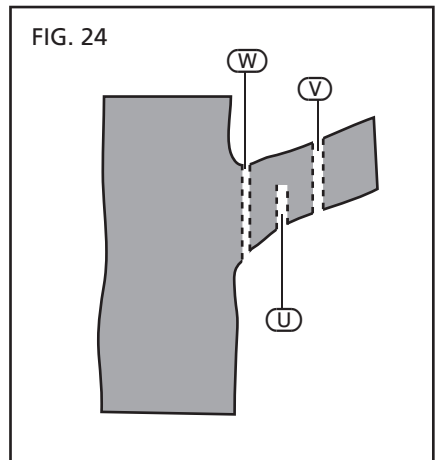

9. OPERATING INSTRUCTIONS

9.11 CROSS CUTTING/BUCKING - FIGS. 25 - 27

Refer to general safety instructions for preparatory and specific warnings.

- Regardless of the supporting method, when cross cutting the compression face of the timber must be initially cut followed by a secondary cut from the other side to meet completing the cut. The initial cut should be one third the diameter and the secondary cut two thirds.
- Incorrectly assessing the tension can result in the chain pinching or the timber splintering.
- For smaller logs always employ the use of a log saw stand/horse. Smaller logs must be secured before cutting commences as the chain speed can cause the log to move and possible kick up.
- Use the spiked bumper to obtain a firm grip and leverage while performing all cuts.

9.12 SAW CHAIN

- The chainsaw is designed for cutting timber only. Do not allow the chain to come into contact with the ground as dirt and soil will dull the chain almost immediately. Hard wood will also rapidly dull the chain.
- When the chain is properly sharpened, work will not be tiring, the cutting yield is high, and there is no abnormal wear on the mechanical parts or the bar.

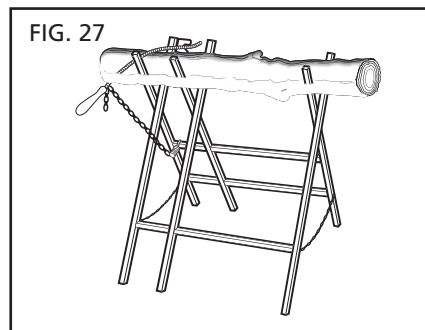
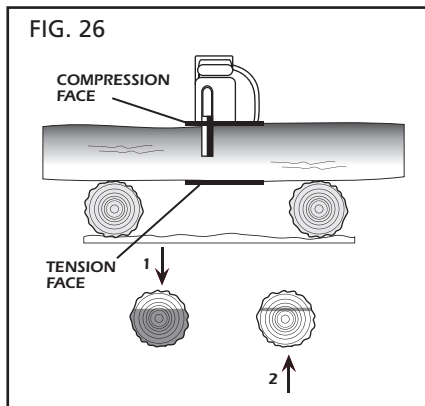
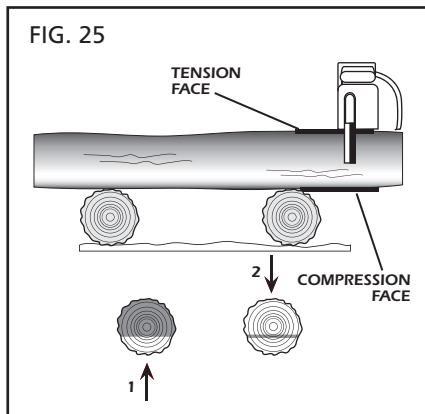

9. OPERATING INSTRUCTIONS

9.13 CHAIN LUBRICATION - FIG. 28

- Prior to use check for chain oil distribution on a piece of paper or cut timber. Observe spatter before continuing.
- If the chain is not sufficiently lubricated, check the oil tank level and/or increase the oil flow by rotating the setting screw (25.1) anti-clockwise. If problem persists, stop engine and when cooled clean sawdust from behind clutch cover and clean bar groove.



9.14 SHARPENING - FIG. 29

- Sawdust instead of chips is an indication that the saw chain needs sharpening, or replacing.
- Before sharpening, the chain must be made taut by means of the chain tensioner.
- After sharpening, slacken and adjust the chain as per the mounting instructions.
- During sharpening, lock the chain using the brake.
- Use a round file specific for the chain fitted. Observe the sharpening angle (Fig.29 parts 2,3,5,7,8).
- Sharpen by filing from the inside outwards (Fig.29 part 9) all the teeth on one side and then all the teeth on the other.
- Position the file to project 20% of its diameter above the cutter (Fig.29 part 6).
- Make sure every cutter is filed to the same length and angle, and that all depth gauge links are the same height (Fig.29 part 1).
- Inconsistent angles can result in a poor cut or endanger the user. Seek advice from a professional if unsure.

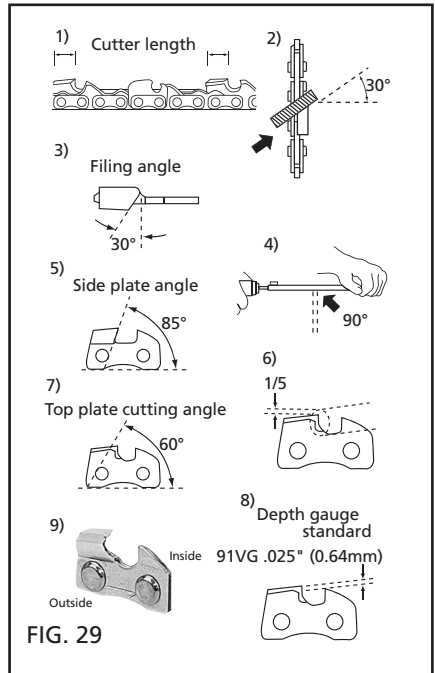

10. MAINTENANCE

Warning:

- Stop engine, allow to cool and engage the chain brake before carrying out maintenance or adjustments to the machine.
- Note: Do not carry out repairs on the machine if you are not qualified to do so, with the exemption of the items listed in this maintenance section.

10.1 CARBURETTOR ADJUSTMENT - FIG.30

Warning:

- During this operation the chain will be moving. Ensure protective equipment is worn and observe all necessary safety precautions.
- Note: The chain **MUST NOT** move while the engine is at idle speed.
- The carburettor on your chainsaw has been set at standard values during manufacture. Adjustments to these values may be required occasionally.
- To adjust, start the engine and allow the machine to idle. If the engine stalls, the idle speed is too low. If the chain moves, the idle speed is too fast. Using a cross slot screwdriver, turn the adjustment screw (13) clockwise to increase engine speed, or anti-clockwise to decrease engine speed.

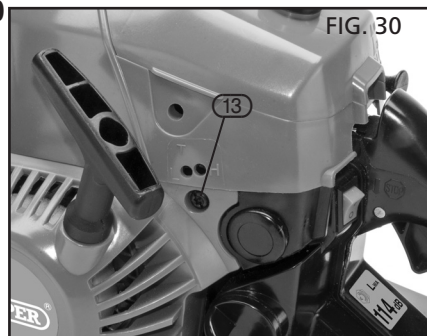

10.2 BAR MAINTENANCE - FIG.31

- Periodically clean the chain run groove and oil passages.
- Lubricate the sprocket wheel with bearing grease.
- Reverse the guide bar on a regular basis to ensure uniform bar wear.
- Burring of the guide bar rails is normal. Remove these burrs as appropriate with a flat file.
- The guide bar should be replaced when the chain run groove is worn, the bar is damaged or if excessive burring or heating occurs.



10.3 AIR FILTER - FIGS. 32 & 33

- A clogged air filter reduces the engine efficiency, consequently reducing cutting effectiveness while increasing fuel consumption.

Note: The air filter should be cleaned more frequently when the wood being cut is dry or the work environment dusty.

- Remove the top cover (8) by loosening securing screw (7).

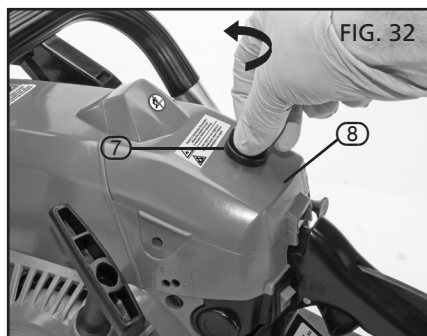

10. MAINTENANCE

- Lift the filter (8.1) from the machine. Blow any loose dirt from inside, outwards. If dirt is hard to remove, wash using hot soapy water. Ensure filter is fully dry before refitting.
- Replace the filter if damaged (deformed or cracked).

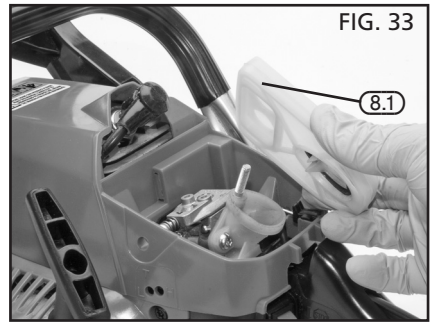

10.4 FUEL FILTER - FIG. 34

- The fuel filter (8.2) should be replaced annually.
- To change the fuel filter, unscrew and remove the fuel tank cap. Using a pair of long nose pliers, gently pull the filter from the fuel tank. Carefully remove the filter from the line and refit new filter.
- Use only a genuine replacement filter.



10. MAINTENANCE

10.5 SPARK PLUG - FIGS. 35 & 36

- The spark plug should be replaced annually or if the chainsaw is experiencing starting problems.
- Remove the top cover to reveal the spark plug. Carefully pull off the spark plug HT lead. Using the box spanner supplied unscrew the plug.
- If the electrodes are excessively soiled or are very worn, replace with a suitable equivalent plug.

Note: Ensure the spark plug has the correct heat range for this machine. Excessive soiling can be due to an incorrect ratio of oil to fuel.

Note: The spark plug gap should be 0.6mm. Use feeler gauges to check the gap.

Note: Do not carry out repairs on the machine if you are not qualified to do so with the exemption of the items listed in this maintenance section.

Danger: In order to maintain the original safety features, do not make any changes to the machine. In case of repairs, use only genuine spare parts.

- Before each use check that there are no loose or damaged parts, cracks and signs of wear.
- Have damaged parts replaced by an authorised service agent before using the machine.

10.6 CLEANING, TRANSPORT & STORAGE

- **Note:** Stop engine and allow to cool before cleaning, transporting or storing the chainsaw.
- Clean the unit after each use. Only use a mild detergent and sponge on plastic surfaces. Do not use aggressive cleaning agents.
- Separation of fuel can lead to acids forming during storage. In order to avoid engine problems empty fuel system if storing for longer than 30 days. Empty the fuel tank, start the engine and allow to run until it stops. Ensure fresh fuel is used next season. Never use engine or carburettor cleaning products in the fuel tank as permanent damage may occur.
- Do not store the machine or fuel in an enclosed area where fuel vapours can reach sparks or flame from switches, heaters, electric motors etc.
- Store in a safe area out of the reach of children.

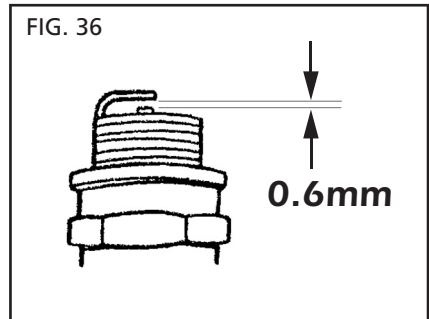
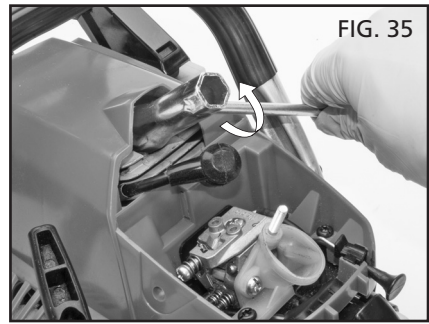

11. TROUBLESHOOTING

WARNING: always stop the unit and disconnect the spark plug prior to performing any of the remedies, except where the remedy requires the engine to be running.

Problem	Probable cause	Suggested remedy
Engine will not start or only runs for a few seconds.	<ol style="list-style-type: none">1. Fuel tank empty.2. No fuel reaching carburettor.3. Engine flooded.4. Stop switch off.5. Spark plug.	<ol style="list-style-type: none">1. Fill with correct fuel/oil mixture.2. Check for a dirty fuel filter; clean or replace. Check for damage to fuel line.3. Wait a few minutes then attempt to start as if engine was warm.4. Move stop switch to on position.5. Clean or replace spark plug.
Engine does not idle correctly.	<ol style="list-style-type: none">1. Carburettor requires adjusting.2. Other.	<ol style="list-style-type: none">1. Adjust carburettor idle.2. Contact authorised service agent.
Engine stutters, lacks power or stalls under load.	<ol style="list-style-type: none">1. Spark plug soiled.2. Air filter dirty.3. Carburettor requires adjusting.	<ol style="list-style-type: none">1. Clean and re-gap or replace.2. Clean or replace air filter.3. Contact authorised service agent.
Chain does not move or is tight.	<ol style="list-style-type: none">1. Chain brake engaged.2. Insufficient chain lubrication.	<ol style="list-style-type: none">1. Disengage chain brake.2. Fill chain oil tank and refill with correct oil/fuel mixture.
Excessive engine smoke.	<ol style="list-style-type: none">1. Too much oil mixed with unleaded fuel.	<ol style="list-style-type: none">1. Empty fuel tank and refill with correct oil/fuel mixture.
Chain moves while engine at idle speed.	<ol style="list-style-type: none">1. Carburettor requires adjusting.2. Clutch fault.	<ol style="list-style-type: none">1. Adjust carburettor idle.2. Contact authorised service agent.

IMPORTANT: Please note all repairs/service should be carried out by an authorised service agent.

12. EXPLANATION OF SYMBOLS

12.1 EXPLANATION OF SYMBOLS



Single value noise marking.
(Maximum declared A-Weighted
sound power level in decibels).



Danger of kickbacks.
Kickbacks can cause
lethal wounds.



Always wear personal protective
equipment, ear defenders, face
protection and helmet.



Warning.



Read the instruction manual.



Always wear gloves.



Always wear safety footwear.

13. DISPOSAL

13.1 DISPOSAL

- At the end of the machine's working life, or when it can no longer be repaired, ensure that it is disposed of according to national regulations.
- Contact your local authority for details of collection schemes in your area.

In all circumstances:

- Do not dispose with domestic waste.
- Do not incinerate.
- Do not abandon in the environment.
- When decommissioning (preparing the machine to be scrapped) drain any remaining fuel and oil for separate disposal.

CONTACTS

- **DRAPER TOOLS LIMITED,**
Hursley Road, Chandler's Ford,
Eastleigh, Hampshire. SO53 1YF. U.K.
- **Helpline:** (023) 8049 4344
- **Sales Desk:** (023) 8049 4333
- **Internet:** www.drapertools.com
- **E-mail:** sales@drapertools.com
- **Sales Fax:** (023) 8049 4209
- **General Enquiries:** (023) 8026 6355
- **Service/Warranty Repair Agent**
For aftersales servicing or warranty repairs, please
contact the Draper Tools Helpline for details of an
agent in your local area.

YOUR DRAPER STOCKIST

KCLJ0218

©Published by Draper Tools Limited.

No part of this publication may be reproduced, stored in a retrieval system or transmitted in any form or by any means, electronic, mechanical photocopying, recording or otherwise without prior permission in writing from Draper Tools Ltd.